

## Flexural Strength of Reinforced Concrete Slabs Strengthened and Repaired by High Strength Ferrocement at Tension Zone

Mohammed N. Mahmood

Professor

Civil Engineering Department, Mosul University

Hassan Sideq Thanoon

Civil Engineer

### Abstract

This paper presents a study of the flexural behavior of strengthened and repaired reinforced concrete slabs by ferrocement. The study includes testing 17 simply supported slabs, which include 2 control slabs, 3 strengthened slabs and 12 repaired slabs. In the strengthened slabs the effect of number of wire mesh layers of ferrocement on the ultimate load, mid span deflection at ultimate load and intensity of cracks were examined. In the repaired part the slabs were stressed to (70 %) of measured ultimate load of control slab. The effects of number of wire mesh layers, ferrocement thickness and the connection method between repaired slabs and ferrocement jacket on the ultimate load, mid span deflection at ultimate load and intensity of cracks were examined.

Keywords: Concrete, ferrocement, repair, slab, strengthening.

### مقاومة الانثناء للبلاطات الخرسانية المسلحة المقواة والمصلحة بغطاء من الفيروسمنت عالي المقاومة في منطقة الشد

حسن صديق ذنون  
مهندس مدني

محمد نجم محمود  
أستاذ

قسم الهندسة المدنية - كلية الهندسة / جامعة الموصل

### الخلاصة

يتضمن البحث الحالي دراسة مقاومة الانثناء للبلاطات المقواة والمصلحة باستخدام الفيروسمنت من خلال تقصي ومقارنة نتائج الفحص لسبعة عشر بلاطة، ثلاث منها مقواة بالفيروسمنت، اثنا عشر بلاطة لدراسة فاعلية عملية الإصلاح وبلاطتان تم أخذهما كبلاطات مرجعية. إن المتغيرات التي تمت دراستها في عملية التقوية هي تأثير عدد طبقات المشبكات السلكية، حيث تم استخدام (2, 3 & 4) طبقات من المشبكات السلكية، على الحمل الأقصى والأود المقابل له بالإضافة إلى تأثيرها على كثافة الشقوق، أما في حالة الإصلاح فقد تم تسليط (70 %) من الحمل الأقصى المأخوذ من البلاطات المرجعية على البلاطات المراد إصلاحها ودراسة تأثير كل من عدد طبقات المشبكات السلكية، حيث تم استخدام (2, 3 & 4) طبقات، وسمك الفيروسمنت، تم استخدام فيروسمنت بسمك (2 & 3 cm)، وطريقة ربط الفيروسمنت بالبلاطة، استخدم أسلوب الربط بواسطة البراغي أو بواسطة الأيبوكسي، على عملية الإصلاح بالفيروسمنت.

Received: 8 – 1 - 2012

Accepted: 5 – 7 - 2012

## 1. Introduction:

Reinforced concrete is the most frequently used structural material because of its good durability, and it has been used for many years to build a wide variety of structures. Consequently little maintenance or repair work is usually required on concrete structures that have been designed and built well with materials of controlled quality, unless they are exposed to particularly aggressive conditions. A period of dynamic growth in its use came during the 1960s as a result of chronic shortage of housing. The commonly held view, that concrete is a durable, maintenance-free construction material has been changed in recent years. Several examples can be shown where concrete did not perform as it was expected. Although hundreds of thousands of successful reinforced concrete structures are annually constructed worldwide, there are large numbers of concrete structures that deteriorate, or become unsafe due to inadequacy of design detailing, construction and quality of concrete, overloading, chemical attacks, corrosion of rebar, foundation settlement, abrasion, fatigue effect, atmospheric effects, abnormal floods, changes in use, changes in configuration and natural disaster, etc. All of these factors affecting the durability of concrete structures and made engineers thought about methods for repairing and rehabilitation of deteriorated concrete structures [1]. This study presents preliminary investigations of structural behavior of strengthened and repaired concrete slab by ferrocement.

## 2. Test Program

Seventeen simply supported slabs were tested. All slabs were rectangular with 500 mm width, 100-130 mm total depth and a total length of 1400 mm. Each reinforced concrete slab is reinforced with  $\text{Ø}10@125\text{mm c/c}$  as a main reinforcement and  $\text{Ø}10@350\text{mm}$  as a secondary reinforcement. The specimens were arranged in three groups; (A-C) as follows:-

- Group A

This group consisted of two specimens; these specimens were the control specimens with normal concrete cover and tested up to failure.

- Group B

This group includes three reinforced concrete slabs strengthened with ferrocement cover. The purpose of this group is to investigate the effect of varying the number of wire mesh in the ferrocement cover. For this purpose three specimens, (B1, B2 & B3) with (1, 2 & 3) layer of wire mesh respectively, were cast and tested. The thickness of these slabs is (100 mm) in which the (20 mm) cover of reinforced concrete is replaced by ferrocement layer.

- Group C

This group consisted of twelve reinforced concrete slabs with (100 mm) thickness. These specimens are loaded (70 %) of the failure load, then these slabs repaired by adding a ferrocement jacket. Specimens of this group divided as follows:

1- six specimens are repaired by adding ferrocement with (20 mm) thickness, the connection method between slab and ferrocement are as follows:-

a) In three of these specimens ferrocement is connected to the bottom face of the slab by (10 mm) diameter bolts spaced at (150 mm c/c) and reinforced with (either 2, 3 or 4) layers of wire mesh.

b) In the other three specimens, ferrocement is connected to the bottom face of the slab by epoxy and the ferrocement jacket is reinforced by (2, 3 or 4) layers of wire mesh.

2- The other six specimens repaired by (30 mm) ferrocement jacket and these slabs are divided into the following two groups:-



Table 1: details of specimen

Croup	The purpose	No. of specimens	Ferrocement thickness (mm)	total slab thickness (mm)	No. of wire mesh	Connection method
A	control	A1	-----	100	-----	-----
		A2				
B	strengthened	SB-2	20	100	2	monolithic
		SB-3			3	
		SB-4			4	
C	Repaired	Sc-2-20- <sub>B</sub> E	20	120	2	By bolts or (epoxy)
		Sc-3-20- <sub>B</sub> E			3	
		Sc-4-20- <sub>B</sub> E			4	
		Sc-2-30- <sub>B</sub> E	30	130	2	By bolts or (epoxy)
		Sc-3-30- <sub>B</sub> E			3	
		Sc-4-30- <sub>B</sub> E			4	

### 3. Materials

Iraqi Portland cement (Badoosh) satisfied the specification (IQS:5/1984)[2] (table 2 and table 3 contain the chemical and physical properties of cement respectively), natural sand and aggregate with the (10 mm) maximum aggregate size that satisfied the specification (ASTM C33-03)[3](see table 4 and table 5)are used for the concrete (cement: sand: gravel/water) in the ratio of (1:1.6:2.7/0.5 by weight). The concrete mix was design to give 28-days cylinder strength of 30 MPa. The main reinforcement used in all slabs consisted of four (10mm diameter) high tensile steel bars with yield strength of 565 MPa. For ferrocement mortar, Portland cement and natural sand satisfied ACI 549R-97 [4] were used in the ratio of 1:2/0.4 by weight. This mortar gives 28-days strength of (50 MPa) with the aid of using super plasticizer (Sika Viscocrete-5W) with a dosage of (1 % of cement weight). The ferrocement chicken wire was a galvanized welded square mesh of (0.6 mm) diameter and (12.5 mm) openings, the choice of square mesh was related to many studies stated that the type of mesh with square opening is better than any other types of mesh [5]. The mesh tested according to the method described in reference [6] to get its yield strength and it was found to be 350 MPa.

All specimens were cast in molds made of plywood. For strengthened slabs the ferrocement cover was first placed at the bottom with the required number of wire mesh layers followed by placing the slab reinforcement directly on top of the ferrocement cover and then the concrete instantaneously placed (see Fig 2 and Fig 3). For the repaired reinforced concrete slabs (without ferrocement cover), after it was loaded up to (70%) of the failure load which was predicted by the control specimens, was then repaired by ferrocement layer which either fixed to bottom face of the slab by (10 mm) diameter bolts, placed as grid with (250×150 mm) dimension, or by epoxy resin (see Fig 4 and Fig 5) because it has been found that roughening the face of slab was not enough to connect the ferrocement and slab tension face [7].

With each specimen, three cylinders (150mm diameter and 300mm height) were cast to determine the concrete compressive strength [8] and three (50×50×50mm) cubes were cast to determine mortar compressive strength [9], Table 6 include the compressive strength of concrete and mortar for all slabs.

The specimens, were kept covered with wet sacks for 28-day.

Table 2: Chemical properties of cement

Composition of cement	(%)	Specification limit (IQS,5/1984)[23]
AL <sub>2</sub> O <sub>3</sub>	5.6	3-8
SiO <sub>2</sub>	21.52	17-25
Fe <sub>2</sub> O <sub>3</sub>	2.74	0.5-6
SO <sub>3</sub>	2.54	2.8%≥
MgO	3.23	5%≥
compound of cement		
C <sub>3</sub> S	36.44	31.03- 41.05
C <sub>2</sub> S	34.20	28.61 – 37.9
c <sub>3</sub> A	10.20	11.96-12.3
C <sub>4</sub> AF	7098	7.72-8.02

Table 3: physical properties of cement

Time of setting	10% ≤	10% ≥
Time of setting		
Primary (minute)	140	45 minute ≥
finally (minute)	200	≥ 600 minute
Compressive strength (MPa)		
3 days	18.9	(16 MPa) ≥
7 days	26	(24 MPa) ≥
Tensile strength (MPa)		
3 days	1.7	(1.6MPa) ≥
7 days	2.5	(2.4 MPa) ≥

Table 4: specification of used sand

Sieve size	Passing %	Standard
No. 8	100	100
No. 4	98	95-100
No. 8	80	80-100
No.16	64	50-85
No. 30	44	25-60
No. 50	16	5-30
No. 100	6	2-10
F.M.	2.9	
M.A.S	No.4	
A.S.S.	No.30	
Sp. gr.	2.61	

Table 5: specification of used gravel

Sieve size	Passing %	Standard %
In.		
2	100	100
1.5	100	95-100
3/4	57	35-70
3/8	10	10-30
3/16	0.7	0-5
Pan	0	
F.M.	7.3	
M.A.S	1.5 in	
Sp.gr.	2.65	

Table 6: Properties of concrete and mortar

Properties Slabs	f <sub>c</sub> <sup>(1)</sup> (MPa)	f <sub>cm</sub> <sup>(2)</sup> (MPa)	E <sub>c</sub> <sup>(3)</sup> (GPa)	E <sub>m</sub> <sup>(4)</sup> (GPa)
A	33	-----	26	
SB-2	33	53	26	33.6
SB-3	32	52	24	34
SB-4	29	53	26	32
SC-2-20-B	30	51	25	33
SC-3-20-B	32	50	24	33.6
SC-4-20-B	29	52	25	34
SC-2-30-B	33	54	26	32.5
SC-3-30-B	29	49	24	33
SC-4-30-B	29	50	24	33.6
SC-2-20-E	30	52	25	33
SC-3-20-E	33	50	26	34.3
SC-4-20-E	33	55	26	34
SC-2-30-E	32	54	27	32
SC-3-30-E	30	51	25	32.5
SC-4-30-E	29	49	24	34



Fig 2: Placing the wiremesh

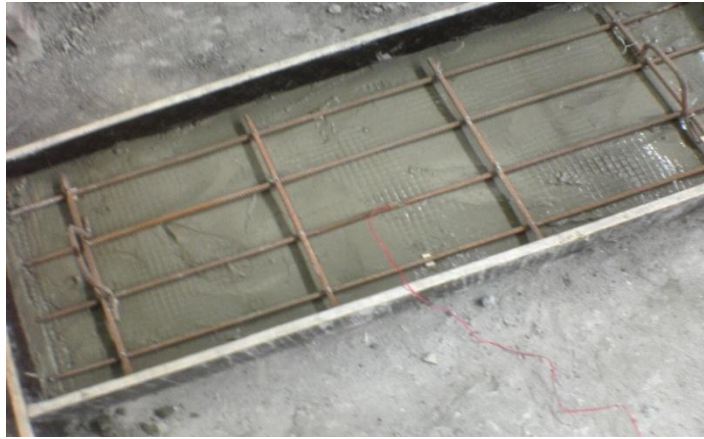

Fig 3: Placing the reinforcement



Fig.4: Placing the bolts to connect the ferrocement cover and repaired slabs



Fig.5: Placing the ferrocement cover connected to repaired slabs by epoxy

#### 4. Test procedures

All slabs were tested under four-point flexural loading over a clear span of 1200mm and instrumented for measuring mid span deflections. Fig. 6 and Fig. 7 show the position of transducer, loading point on the slabs.

All the slabs were tested using an incremental loading procedure. Linear variable displacement transducer (LVTD) was used to measure the mid span deflection of the slab. Portable electronic data logger was used to record the reading of deflections and slip. The initial values for deflections, slips and loads were zeroed on the measuring device and the loading system and transducers was the assembled in position. These conditions were then considered to represent the initial state of the slabs. Out of these seventeen slabs two are control slabs which are tested after 28 days of curing to find out the load carrying capacity, three strengthened slabs were tested to failure, rest of twelve slabs are loaded up to 70 percent of the ultimate load obtained from testing the control slabs.

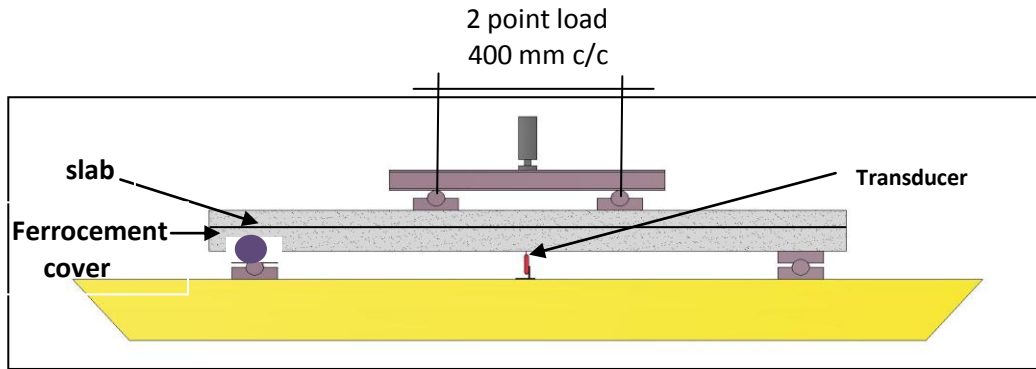

Fig. 6: Test procedur



Fig. 7: Test setup

## 5. Results and discussion

### 5.1 Strengthened slabs:

Fig.8 shows the load-deflection curves for strengthened slabs and table 7 shows the results of strengthened slabs. In general, slabs with ferrocement cover exhibited greater stiffness than the control specimens and greater ultimate load. This ultimate load increased with the increase of wire mesh layers by (2.3, 9, 16.6 %) when using (2, 3 &4) wire mesh layers respectively. From Fig. 8 it can be noticed that the Increase of wire mesh layers did not significantly reduce the total deflection and the deflection increase due to the increase of ultimate load but it was still less than the deflection at ultimate load in control slab.

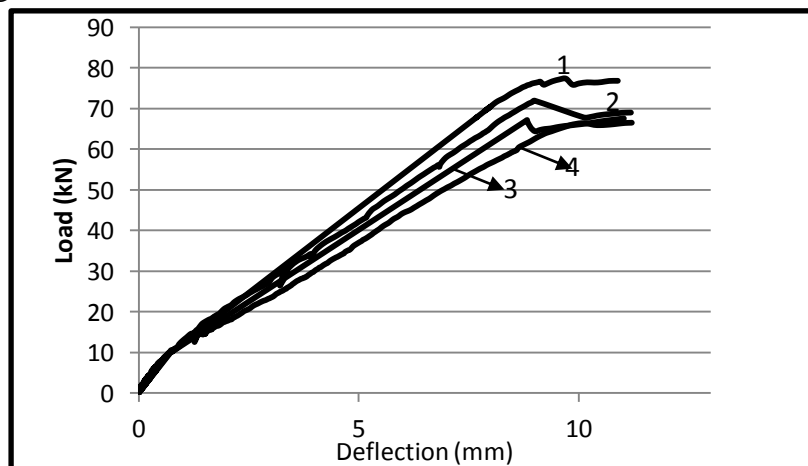

Fig. 8: Load-deflection curve of strengthened slabs

5.2 Repaired slabs

Fig. (9-12) Show the load-deflection curves for repaired slabs.

Table 7: results of strengthened slabs

specimen	total thickness (mm)	No. of wire mesh layer	Ultimate load (kN)	% increase 1:A 2:SB-2 3:SB-3 4:SB-4	Deflection at ultimate load
A	100	-----	66		10.35
SB-2	100	2	67.5		8.8
SB-3	100	3	71	7.5	9
SB-4	100	4	77	16.6	9.7

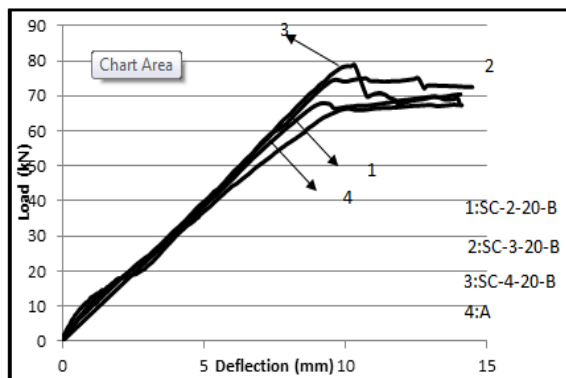

Fig. 9: Load-deflection curve of group1

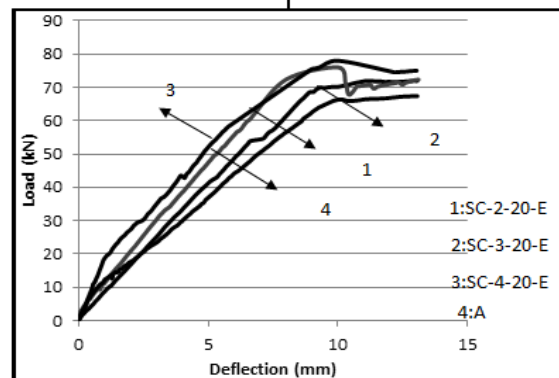

Fig. 10: Load-deflection curve of group2

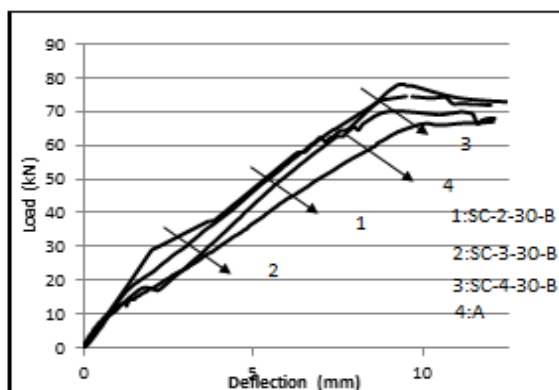

Fig. 11: Load-deflection curve of group3

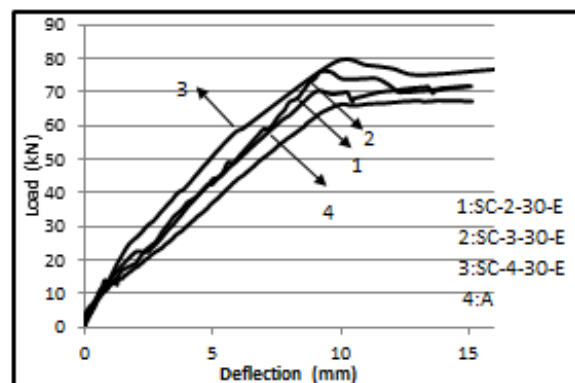

Fig. 12: Load-deflection curve of group4



5.2.1 Ultimate load

The ultimate load of repaired slabs are given in Table 8.

Table8: Ultimate load of repaired slabs

group No.	Specimen	Steel ratio	Minimum steel ratio	Volume fraction of wire mesh	Ultimate load (kN)	% increase of ultimate load
	<b>A</b>			-----	66	-----
<b>1</b>	<b>SC-2-20-B</b>	0.0084	0.002	0.002262	68	3
	<b>SC-3-20-B</b>			0.003393	74	12
	<b>SC-4-20-B</b>			0.004524	78.5	19
<b>2</b>	<b>SC-2-20-E</b>			0.002262	69	4.5
	<b>SC-3-20-E</b>			0.003393	76	15
	<b>SC-4-20-E</b>			0.004524	78	18
<b>3</b>	<b>SC-2-30-B</b>			0.001508	70	6
	<b>SC-3-30-B</b>			0.002262	74.4	12.7
	<b>SC-4-30-B</b>			0.003016	78	18
<b>4</b>	<b>SC-2-30-E</b>			0.001508	70	6
	<b>SC-3-30-E</b>			0.002262	76	15
	<b>SC-4-30-E</b>			0.003016	79	19.7

The results above show that the addition of ferrocement not only restored the strength of deteriorated slab but also caused to increase its ultimate strength. The table shows that the increase of ultimate load compared with the control specimens (A) is mainly affected by the number of wire mesh layers, while the thickness of ferrocement and method of connecting the ferrocement with the reinforced concrete slabs has only a marginal effect on the ultimate load of repaired slabs. By comparing the results of group 1 with group 2 and that of group 3 with group 4 it may be noted that using epoxy to adhere the ferrocement jacket to the bottom face of the slab gave a higher ultimate load compared with that in which the ferrocement jacket is fixed by steel bolts. Fig13 shows the percentage increase of ultimate load compared to control slab.

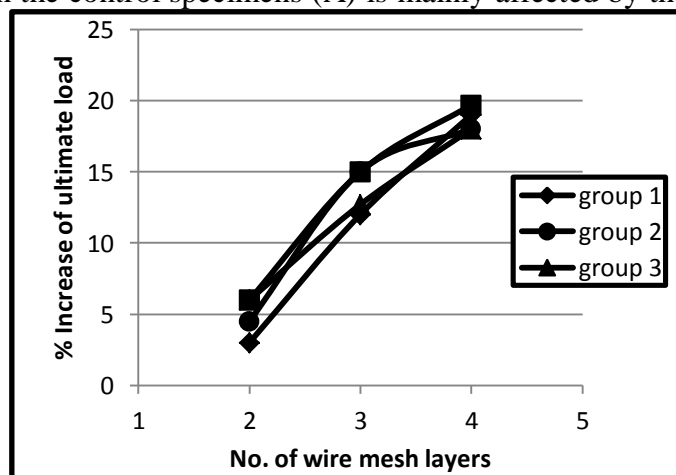

Fig. 13: Effect of number of wire mesh layers on the ultimate load

### 5.2.3 Cracks intensity

Cracks intensity of slabs computed by taking a photo for slab at failure load using HD digital camera with 16 megapixels and create a diagram of cracks pattern by Photoshop 7.0 program (see Fig 14). Then the cracks intensity was computed by calculating the area of cracks using (MoticImagee 2.0 program) divided by the area of slab face.

The cracks intensity for the repaired slabs is given in Table 9.



Fig 14: Cracks Pattern of Control Slab (A)

Table 9: Cracks intensity for repaired slabs

group No.	Specimen	Total thickness (mm)	Connection method	No. of wire mesh layers	Cracks intensity ( $\text{mm}^2/\text{mm}^2$ )	% Decrease of cracks intensity
	<b>A</b>	100	-----	-----	0.0162	-----
<b>1</b>	<b>SC-2-20-B</b>	120	by bolts	2	0.013	19.75
	<b>SC-3-20-B</b>			3	0.01	38
	<b>SC-4-20-B</b>			4	0.007	56.8
<b>2</b>	<b>SC-2-20-E</b>	120	by epoxy	2	0.01	38
	<b>SC-3-20-E</b>			3	0.0093	42.6
	<b>SC-4-20-E</b>			4	0.0062	61.7
<b>3</b>	<b>SC-2-30-B</b>	130	by bolts	2	0.014	13.6
	<b>SC-3-30-B</b>			3	0.013	19.75
	<b>SC-4-30-B</b>			4	0.0086	47
<b>4</b>	<b>SC-2-30-E</b>	130	by epoxy	2	0.012	25.9
	<b>SC-3-30-E</b>			3	0.011	32
	<b>SC-4-30-E</b>			4	0.0074	54

It is clear from the results above that the addition of ferrocement jacket, using different number of wire mesh layers and thickness with any connection method, caused a significant reduce the cracks intensity. And to show the effect of every parameter (No. of wire mesh,

ferrocement thickness and connection method) on the cracks intensity it is necessary to draw the relation between number of wire mesh layers with the percentage decrease of crack intensity of all groups as shown in Fig.15.

The conclusion that can be stated from the figure above is that by increasing the number of wire mesh layers in any group led to decrease cracks intensity. And this due to the increase in specific surface of ferrocement reinforcement (specific surface is the total bonded area of reinforcement (interface area) per unit volume of composite). On the other hand; increasing of ferrocement thickness from 20 mm to 30 mm caused a reduction in the percentage of cracks intensity due to the reduction in specific surface of ferrocement reinforcement caused by increasing ferrocement volume and that can be clearly noticed by comparing between (group1 with group3 and group2 with group4). The connection method was also had also clear effects on cracks intensity and this can clearly be shown when making a comprehension between (group1 with group2 and group3 with group4). As shown in table 9 the reduction in cracks intensity for slabs repaired by ferrocement using epoxy resin as a connection method was higher than that when bolts are used as connection tools.

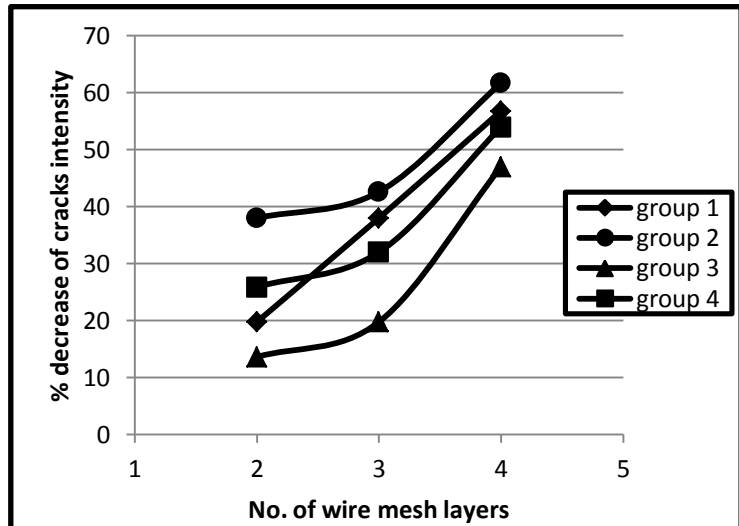

Fig. 15: Effect of number of wire mesh layers on cracks intensity

## 6. Conclusion

Based on the test results obtained from the experimental study, the following conclusions may be drawn out:-

- 1- The preliminary investigation reported in this study indicates that replacing the concrete cover of steel in reinforced concrete slab with ferrocement cover which is constructed monolithically has a significant effect on increasing the strength of slabs in terms of ultimate load and deflection.
- 2- The major factor that affects the strength of strengthened and repaired slabs is the number of wire mesh layers of ferrocement.
- 3- Increasing the thickness of ferrocement has only marginal effects in enhancing the ultimate load of slabs.
- 4- Increasing of wire mesh layers considerably decreased the cracks intensity.

## 7. References:

1. Jummat, M.Z., Kabir, M.H., and Obaydullah, M., "A Review of the Repair of Reinforced Concrete Beams", Journal of Applied Science Research, Department of civil engineering, University of Malaya, 2006.
2. IQS (5), "Specification of Ordinary Portland Cement", Iraq, 1984.

3. ASTM C33-03," Standard Specification for Concrete Aggregates", American Society for Testing and Material, approved June 10, 2003.
4. ACI Committee 549R-97, "Guide for the design construction and repair of ferrocement", Farmington hills, Michigan, 1993.
5. Alniaeeme, S.A., "Nonlinear Finite Element Analysis of Ferrocement Shell Roofs", M.sc. Thesis, University of Mosul, Civil Engineering Department, Mosul, Iraq, 2006.
6. Naaman, A. E., "Ferrocement & Laminated Cementitious Composites", Techno press 3000, Michigan, USA, 2000.
7. Hani, H., and Husam, N., "Experimental and Analytical Investigation of Ferrocement-Concrete Composite Beams", Cement & Concrete Composites, 2003, 26:787-796, Department of Civil and Environmental Engineering, Rutgers, The State University of New Jersey, 98 Brett Road, Piscataway, NJ 08854, USA.
8. ASTM C 39/C 39M-99," Standard Test Method for Compressive Strength of Cylindrical Concrete Specimens1r", American Society for Testing and Material, approved Jan. 10, 1999.
9. ASTM C109-99," Standard Test Method for Compressive strength of Hydraulic Cement Mortar", American Society for Testing and Material, approved Jan. 10, 1999.

The work was carried out at the college of Engineering. University of Mosul